

Rappaport AMP-1 PSU

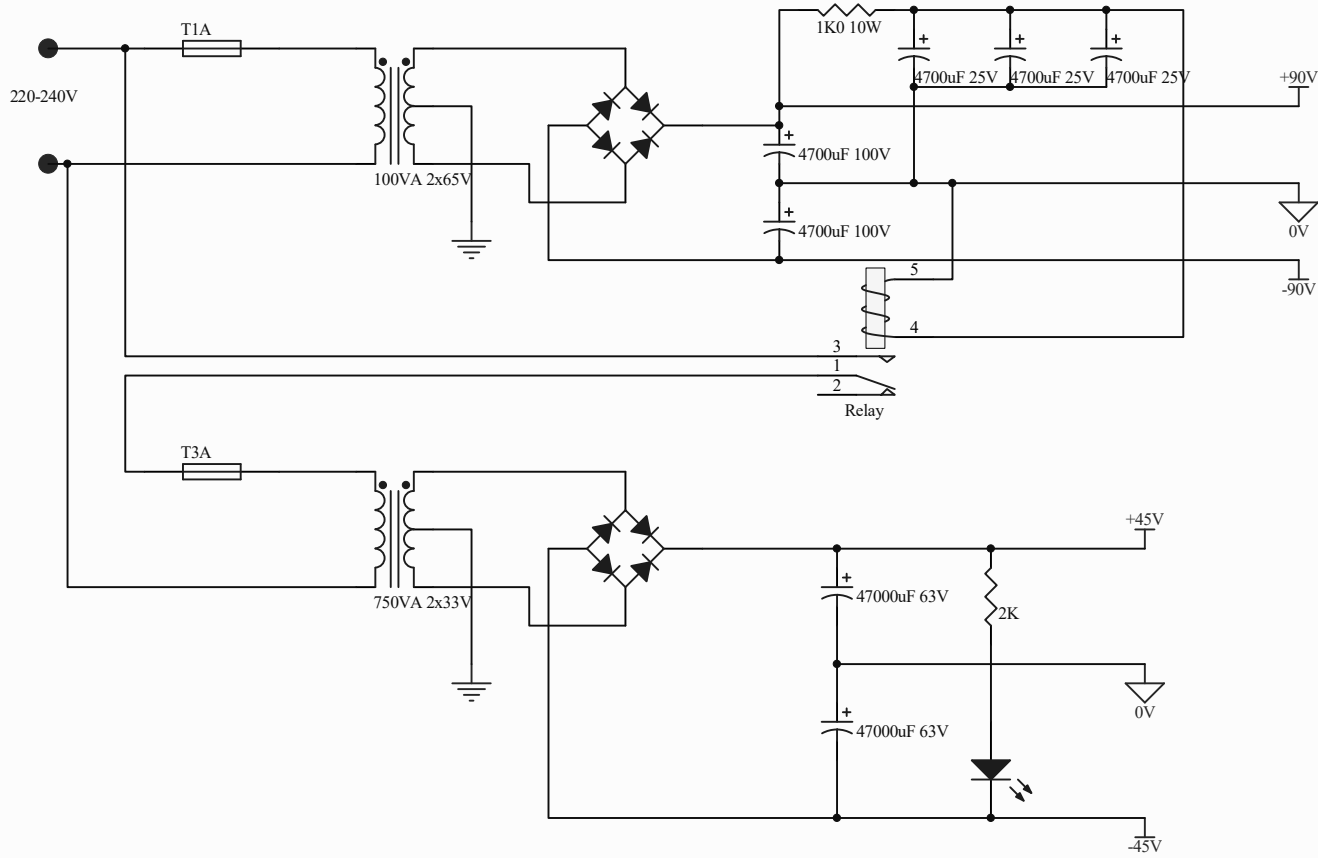

Notes:

1. Separate PSU per Channel
2. Note Transformer CT connection - this needs validating and that it was not connected to 0V

